



SPANISH NATIONAL CHAMPIONSHIP & SPANISH OPEN 2023

BULLETIN 1

06 March, 2023





INDEX

- Dates
- Specialities and Categories
- Competition Programmes
- Rules and Regulations
- Training Flights
- Organising Team
- Officials
- Venues
- Calendar
- Logistics
- Registration
- Annexes
 - 1 Aeronautical Charts
 - 2 Known-Free Programme Regulations
 - 3 CEVA 2023 Mandatory Figures and Programmes



Dear friends,

Happy 2023! We face this season again with the same objectives as last year, to increase the number of national and international pilots that will take part in the Spanish Open and CEVA, to get as much media presence as possible for our sport and to develop the competition formula that will make us attractive to the public.

But, although everything is moving in the right direction, this year we are in mourning. One of the mainstays of CEVA and general aviation and at the heart of almost all of our air sports, Beatriz Melgar, has left us. There are no words to describe our loss as friends and as an aerobatic community. The 2023 Spanish Open and CEVA will be dedicated to her, who helped us so much to get where we are today.

In line with last year, the 2023 CEVA will take place in two venues; both being unique airfields: the small and friendly Matilla de los Caños airfield, in Valladolid, for the initial categories, and the La Caminera Country Club, in Ciudad Real, for the Advanced, the Unlimited and the Freestyle competition. This combination has given excellent results in previous years, as it allows the higher-level pilots to support the novice pilots at Matilla, and the novice pilots to participate as volunteers at La Caminera. In addition, it provides us with an optimal platform for sponsors and media.

In this edition of the CEVA, we expect an even more diverse presence in the Open and hope that you, as international pilots, find it a relevant competition both in sporting terms as well as a promotional platform, thanks to real-time scoring and the live streaming.

From the Club Acrobático Central we are humbly committed to do everything possible to offer the best possible service and attention in terms of organization. The pilots are the heart of CEVA and the Spanish Open, and we will do everything in our power to ensure that this competition is best in class and reaches the greatest number of fans and spectators, as we all grow in media presence, which we hope will facilitate access to new sources of funding for each of you and popularise the sport. If you want to take a look at last year's event, visit CEVA.aero or <https://www.youtube.com/watch?v=3fAH6sP4U7s>

That's all there is for now. It's going to be a good year!

Best regards,

Cástor Fantoba
President
Club Acrobático Central



Dates

CEVA 1 (Classic)

Elementary, Sportsman and Intermediate categories	22 - 24 June 2023
Rain day	25 June 2023

CEVA 2 (Classic)

Advanced and Unlimited categories	06 - 08 July 2023
Freestyle	08 July 2023
Rain day	09 July 2023

Specialities and Categories

The Spanish National Aerobatic Championships and Spanish Open 2023 will be held in the powered aerobatics in Unlimited, Advanced, Intermediate, Sportsman and Elementary categories. The Spanish Freestyle Championship will also be held.

CEVA 2023 Competition Programmes

Elementary Category	2 Compulsory programmes (same)
Sportsman Category	1 Compulsory programme & 1 Unknown programme*
Intermediate Category	1 Compulsory programme & 1 Unknown programme**
Advanced Category	1 Compulsory programme and 2 Unknown programmes**
Unlimited Category	1 Compulsory programme and 2 Unknown programmes
Freestyle	1 4-minute programme with music

In the Advanced and Unlimited (CEVA 2) categories, the Free-Unknown programme (compulsory) and two Unknown programmes will be flown. The Unknowns will be created by Nikolai Nikityuk.

*The Unknown programmes in the Sportsman and Intermediate categories will be composed of the same figures that make up the compulsory programmes (which are listed in Annex 3 of this Bulletin), although in a different order and with small changes, to facilitate the construction of the programmes.

**In the Intermediate category, pilots may use the programme attached in Annex 3, or choose to design their own compulsory programme in accordance with CIVA regulations.

In the Elementary category, pilots will fly twice the official Q-programme, which is included in Annex 3.

Freestyle Competition

The selection of pilots for the Freestyle is limited to pilots in the Unlimited category and upon invitation by the organisers. Those pilots selected will be notified directly and to comply with the music broadcasting rights canons.



Organising Team

The organisation, under the baton of the Club Acrobático Central (CAC), has the management team and the experience accumulated over more than 20 years of activity, to manage aerobatic competitions of the highest level. The CAC was the organiser for seven consecutive years of the Copa Triangular de Vuelo Acrobático (Triangular Cup), a competition that produced world-class pilots.

Officials

Competition Directors	CEVA 1	Cástor Fantoba
	CEVA 2	Irene Pasini
Chief Judge	Nikolai Nikityuk	
Judges	Guy Auger – FAI International Judge	
	Eladi Lozano – FAI International Judge	
	Gonzalo Rodriguez, RFAE Judge	

We will be announcing additional judges in Bulletin 2.

Starter	Juan Socías, Former ENVA Member, RFAE National Judge
Safety Pilots	Rafa Molina Manuel Coco Rey Camilo Benito

Venues

The CEVA 1, which will host the Elementary, Sportsman and Intermediate categories will be held at the Matilla de los Caños Airfield (LETC), which is located about 20 kilometres from the city of Valladolid.

The CEVA 2, host of the Advanced and Unlimited categories, as well as the Spanish Freestyle Championship, will be held at La Caminera Country Club (LENE).

Average Sunrise and Sunset will be: 06:46 and 21:46

CEVA 1 & Spanish Open: Elementary, Sportsman & Intermediate

JUNE

Monday 19 to Wednesday 21	09:00-20:00	Free Practice
Thursday 22	12:00-20:00	Registration and Official Training (1 compulsory safety flight)
	20:15-21:00	Briefing for Organization
Friday 23	09:00-09:30	GENERAL BRIEFING (compulsory)
	10:30-20:30	Competition Flights
Saturday 24	09:00-09:30	GENERAL BRIEFING (compulsory)
	10:00-20:00	Competition Flights
	20:30-21:30	Master Class & Unlimited Team Training flights
	21:45	Prize Giving & Official Dinner
Sunday 25	10:00-14:00	Rain Day Departure

CEVA 2 & Spanish Open: Advanced & Unlimited and CEVA Freestyle

JULY

Monday 03 to Wednesday 05	10:00-20:00	Free Practice
Thursday 06	10:00-14:00 14:00-15:00 16:00-16:30 17:00-20:30	Registration and Official Training (safety flight) Briefing for Organization GENERAL BRIEFING (mandatory) Official Training Flights
Friday 07	09:00-09:30 10:30-19:00 20:00-21:15	GENERAL BRIEFING (compulsory) Competition Flights Freestyle Training Flights
Saturday 08	10:00-10:30 11:00-19:30 19:30 20:00 21:00	GENERAL BRIEFING (compulsory) Competition Flights (Classical & Freestyle) Master Class Formation flight (Yak 52's) Prize Giving Cocktail Reception and Official Dinner
Sunday 09	10:00-14:30	Rain Day Departure

Logistics

CEVA 1

With an asphalted runway of about 1,000 metres, the Matilla Aerodrome in Matilla de los Caños has complete facilities, a restaurant, pool, maintenance centre and hangar. It is an ideal centre for all aviation sports.

There are several hotels in the area, but we recommend booking as soon as possible as there are several cultural activities in Valladolid these dates and hotels are filling up.

Hotel Pago del Olivo

info@pagodelolivo.com

Hotel Los Toreros/Hotel Doña Carmen/Hotel Torreros Trabancos

<https://hotellostoreros.com>

info@hotellostoreros.com

Hotel Montico

<https://www.hotelmontico.com>

CEVA 2 and Freestyle

La Caminera has a 1.400 metre asphalted runway with an elevation of 766 metres. (LENE)

Further specifications are available through the QR.

All CEVA 2 participants will be able to stay at La Caminera Country Club at a special price of €90/night for a single and €108/night for a double. Rates include breakfast and access to the SPA.

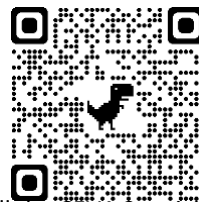

We encourage everyone to stay at La Caminera, as this is where all the CEVA 2 activities will take place. Please book directly, identifying yourself as a CEVA 2022 pilot. We will then validate that you are registered in the competition with them directly and they will apply the special rate. These rates are for pilots competing and spouses/partners. Standard rates apply to family and others (sponsors, etc.).

There are 2 restaurants, meeting rooms, spa, swimming pool and golf. Avgas and oil will be available (for sale) for training flights two days before each event.



Registration

The registration fee for pilots remains the same as 2021 and 2022, remaining unchanged at €350. Please fill in the registration form on the CEVA website. The registration fee includes fuel for the competition flights, on competition days. At both airfields', hangar space will be free of charge, although places are limited. Priority will be given to wood and fabric aircraft.

Participating pilots must:

- Be a member of a club affiliated to RFAE with a national licence, or in the case of foreigners, hold a current federation licence from their country, or a current FAI licence.
- Hold a licence that allows them to fly in the aircraft in which they are competing.
- Hold a valid medical certificate corresponding to the licence they are using.
- Hold an aerobatic rating, if required in the country where their pilot licence was issued.

Participating aircraft must have:

- Certificate of Registration
- A valid Certificate of Airworthiness or Permit to Fly.
- Insurance in force with the third-party coverage indicated in the applicable regulations.
- Aerobatic capability to perform the manoeuvres to be carried out with it.

Payment (please) by bank transfer to RFAE. La Caixa: IBAN: ES26 2100 8739 9122 0002 3876

You must indicate in the concept of the transfer the text: REGISTRATION CEVA 2023 PILOT (name and surname) and CATEGORY.

It is necessary to complete the online registration of pilots for CEVA 2023 at <https://www.ceva.aero> before 30 May as the real time scoring requires all pilots to provide their programmes in advance for uploading and validation. No exceptions will be made.

Any questions you may have will be answered at pilotos@CEVA.aero

Admission rights to the host airfields are reserved at the sole discretion of the CAC and the airport management.

REGRETFULLY NO GENERAL PUBLIC OR NON-COMPETING PILOTS ARE ALLOWED TO ACCESS THE CEVA PLATFORM DURING THE COMPETITION.

ANNEX 1

CEVA 1 – Aeronautical Charts and Aerobatic Boxes

**MATILLA DE
LOS CAÑOS
SPAIN**

(19-2) 25 SEP 16

JEPPESEN

NON CONTROLLED MATILLA AIRPORT FREQ. **123.500 MHz**

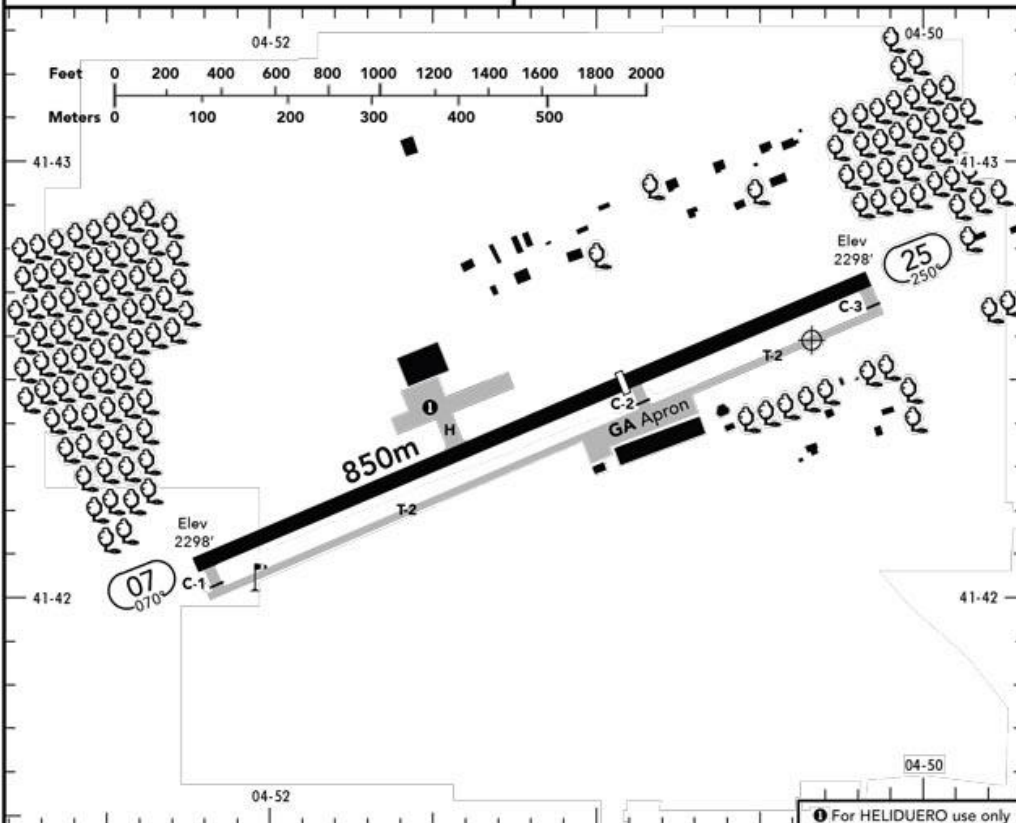

X TAXI

N/A Operaciones solo de orto a ocaso SR - SS HJ

RWY No	Dimension (m) - Surface	TORA (m)	LDA (m)	Strength	Lights
07 25	850 x 18 Asphalt	850	535	PCN 100/F/A/W/T	—

For HELIDUERO use only

ACFT deberá reportar su posición a 5 minutos por el sur sobre Serrada, por el norte sobre Mota del Marques. Procederan desde los puntos de notificación hasta el trafico a 1500' SFC.
 Traficos viniendo del sur deberan sobrevolar la pista manteniendo 1500' SFC e incorporarse al circuito de trafico descendiendo a 800' SFC.
 Traficos viniendo por el norte deberan incorporarse al trafico a 800' SFC si quieren sobrevolar la pista mantendran 1500' SFC y sobre la pista virarán al lado del trafico.
Circuito de trafico:
 Circuitos de trafico a 800' SFC por el norte del campo.
 RWY 25 traficos a derechas. No extender el tramo de viento en cola mas de 1 MN.
 RWY 07 traficos a izquierdas. No extender el tramo de viento en cara mas de 1 MN.
Fallo de radio:
 ACFT con fallo de radio deberá mantener 500' SFC y hacer un trafico por el sur del campo manteniendo 500'.
Precaución:
 Consultar en la web días que permanecera cerrada la RWY por competiciones.
 Se realizan ejercicios de paracaidismo de manera periodica. Consultar web para procedimientos aplicables.
 No extender eje de pista por el este mas de 1 MN sin contactar con Valladolid, CTR clase D.

CHANGES: Puntos de notificación

© JEPPESEN, 1999, 2012. ALL RIGHTS RESERVED.

Aerobatic Box
CEVA 1 (Matilla de los Caños)
North Box

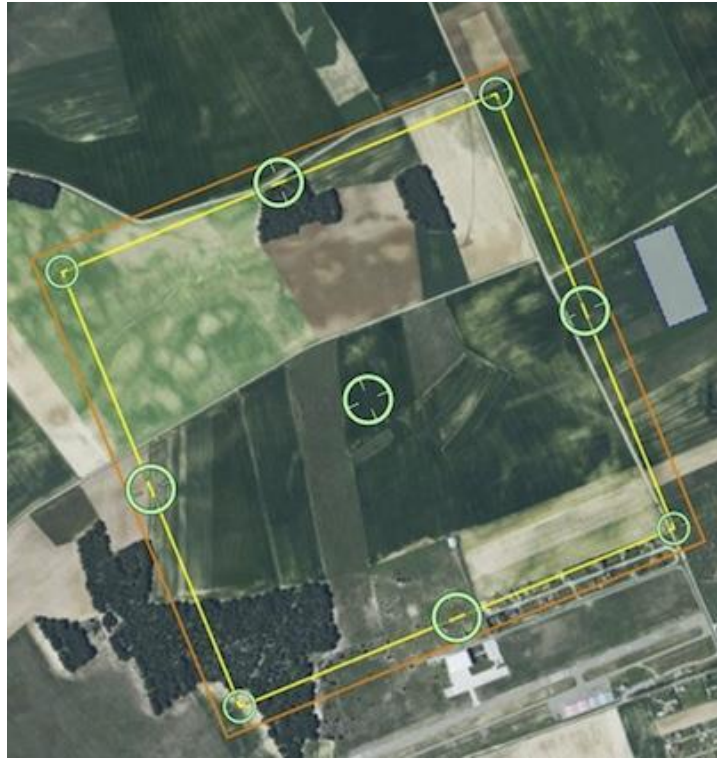

South Box



CEVA 2 y Freestyle (La Caminera)

Aerobic Box

<https://fishh.salshotels.com/files/files/ficha-tecnica.pdf>





ANNEX 2

CIVA Free-Known Regulation

(Applicable only to Unlimited and Advanced in this CEVA)

In accordance with the CIVA Sporting code, section 6, Part 1, Powered Aircraft

Version 2023 pending publication by CIVA

ANNEX 3

Figures for the Compulsory or *Free-Known* Programmes

Unlimited D Total K 231

<p>Fig A 5.2.1.1(17) 9.10.6.3(19) 9.4.5.3(8) K: 44</p>	<p>Fig B 7.2.2.1(6) 9.4.3.2(5) 9.1.3.6(10) 9.9.3.6(14) 9.8.3.4(15) K: 50</p>	<p>Fig C 8.4.16.4(14) 9.9.9.4(13) 9.1.4.2(4) 9.8.2.2(9) K: 40</p>	<p>Fig D 1.2.7.1(13) 9.2.1.4(13) 9.10.4.3(13) 9.1.4.5(9) K: 48</p>	<p>Fig E 8.8.3.4(20) 9.12.1.4(7) 9.1.5.1(2) 9.2.1.6(17) 9.8.5.1(3) K: 49</p>
--	--	---	--	--

Advanced F Total K 173

<p>Fig A 5.2.1.4(22) 9.1.1.3(10) 9.9.5.3(11) K: 43</p>	<p>Fig B 7.2.3.3(6) 9.4.3.2(5) 9.1.3.3(6) 9.4.3.3(8) K: 25</p>	<p>Fig C 8.5.7.1(12) 9.1.3.6(10) 9.9.4.4(11) K: 33</p>	<p>Fig D 7.2.2.1(6) 9.1.3.4(8) 9.9.3.4(11) 9.8.3.2(7) K: 32</p>	<p>Fig E 8.8.1.1(18) 9.4.1.2(9) 9.1.5.3(6) 9.8.1.1(7) K: 40</p>
--	--	--	---	---

Intermediate Yak52 A Total K 109

<p>Fig A 1.2.8.3(15) 9.11.1.6(3) 9.4.2.2(7) K: 25</p>	<p>Fig B 5.3.1.1(18) 9.8.5.1(3) K: 21</p>	<p>Fig C 8.4.3.1(15) 9.1.1.1(6) K: 21</p>	<p>Fig D 8.5.7.3(10) 9.1.3.3(6) 9.1.3.1(2) 9.1.2.4(10) K: 28</p>	<p>Fig E 7.4.3.1(14) K: 14</p>
---	---	---	--	--

Programme - Elementary 2022

CEVA

<https://openaero.net>



Sportman CEVA 2023		Form B
Pilot ID		Flight #

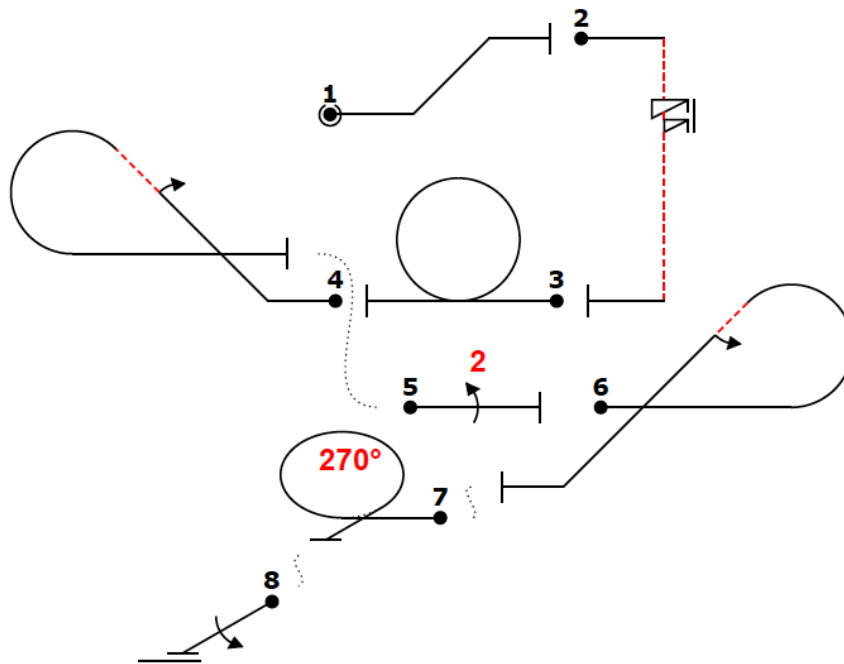
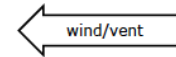

Power			
Fig	Aresti	K	
1	1.1.2.1	7	7
2	1.1.6.3 9.11.1.6	10 3	13
3	7.4.1.1	10	10
4	8.5.2.1 9.1.2.2	10 6	16
5	1.1.1.1 9.2.3.4	2 9	11
6	8.5.6.1 9.1.4.2	10 4	14
7	2.3.1.1	5	5
8	1.1.1.1 9.1.3.4	2 8	10
Total K = 86			

Programme - Sportsman 2022

EVA

<https://openaero.net>



Sportman CEVA 2023		Form B
Pilot ID		Flight #

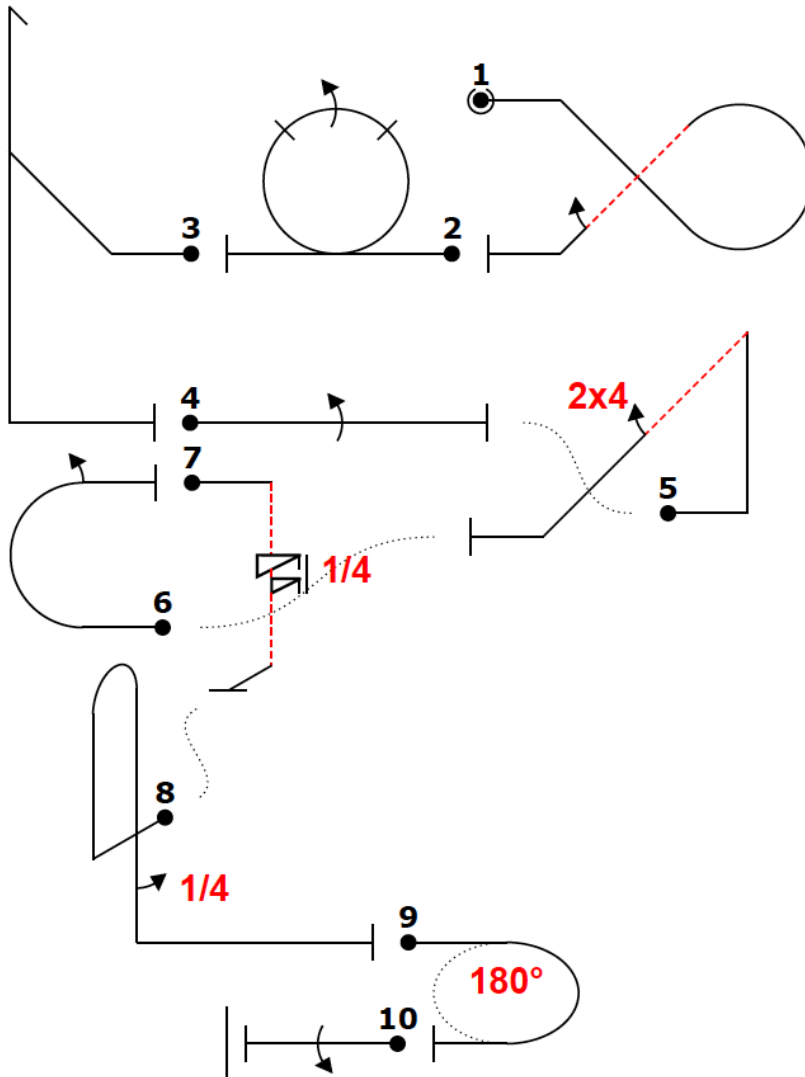
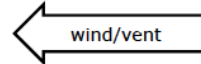

Power			
Fig	Aresti	K	
1	7.3.3.3 9.1.4.2	14 4	18
2	7.4.1.1 9.1.3.4	10 8	18
3	5.3.1.1	18	18
4	1.1.1.1 9.1.3.4	2 8	10
5	1.2.7.1 9.4.4.2	13 5	18
6	7.2.2.1 9.1.3.2	6 4	10
7	1.1.6.3 9.11.1.5	10 4	14
8	8.4.1.1 9.1.5.1	13 2	15
9	2.2.1.1	4	4
10	1.1.1.1 9.1.3.4	2 8	10
Total K = 135			

Proposed programme - Intermediate 2022



B	Contest:	CEVA 1 23	Category:	Power Intermediate
	Date:	25/6/23	Program:	Free Known
			Pilot's No.	

Pilot: Loureiro

wind direction

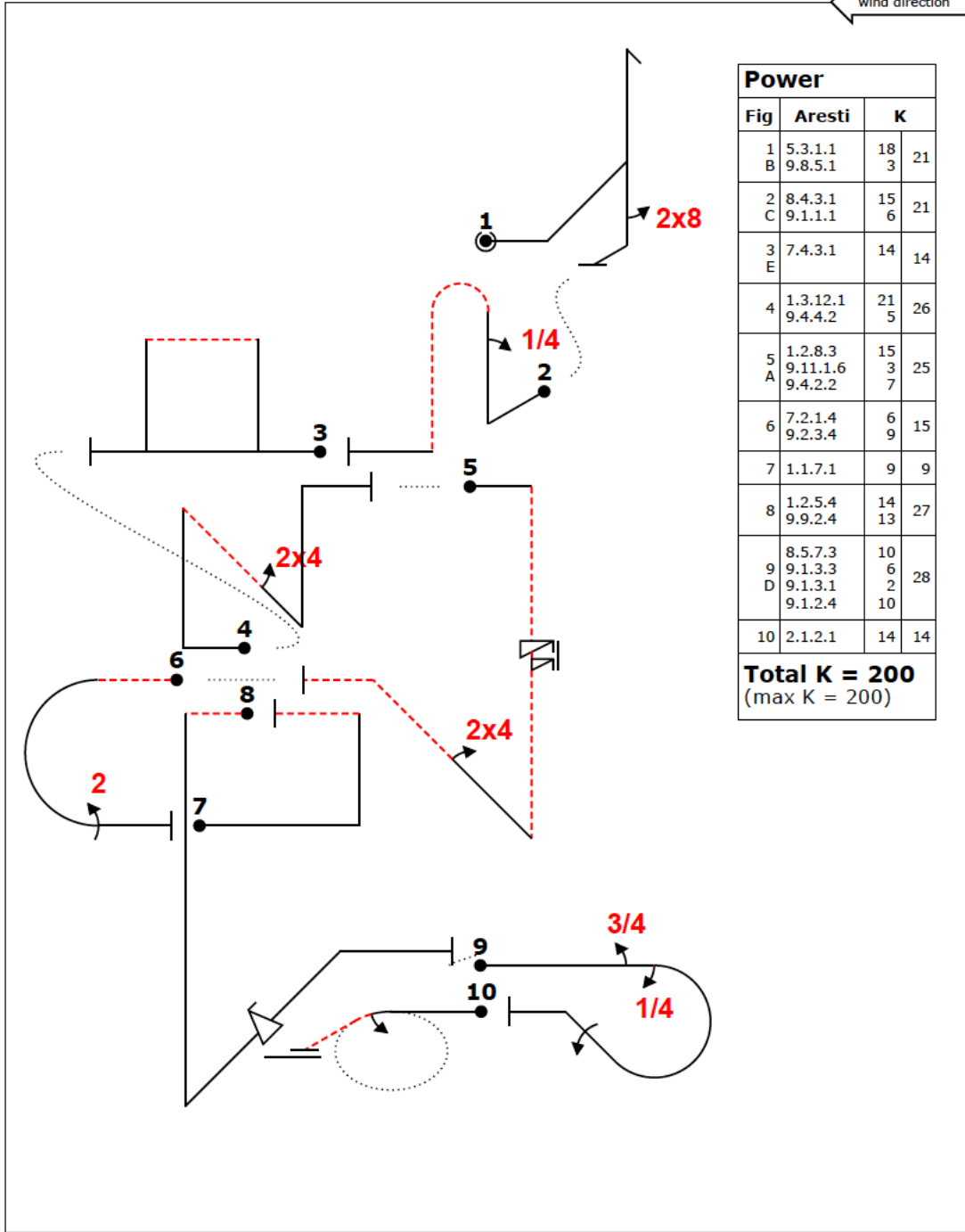

Power			
Fig	Aresti	K	
1	5.3.1.1	18	21
B	9.8.5.1	3	
2	8.4.3.1	15	21
C	9.1.1.1	6	
3	7.4.3.1	14	14
4	1.3.12.1	21	26
	9.4.4.2	5	
5	1.2.8.3	15	25
A	9.11.1.6	3	
	9.4.2.2	7	
6	7.2.1.4	6	15
	9.2.3.4	9	
7	1.1.7.1	9	9
8	1.2.5.4	14	27
	9.9.2.4	13	
9	8.5.7.3	10	28
D	9.1.3.3	6	
	9.1.3.1	2	
	9.1.2.4	10	
10	2.1.2.1	14	14
Total K = 200			
(max K = 200)			